



CATEGORY:

**CLEARED**

---

ADDRESS  
CONTACT IF FOUND:

09/07/00  
JC685 U.S. PTO

A/R E

Attorney Docket No. 7175/65430  
PATENT

Box PATENT APPLICATION  
ASSISTANT COMMISSIONER FOR PATENTS  
Washington, D.C. 20231

JC406 U.S. PTO  
09/660433

Sir:

Transmitted herewith for filing is the reissue patent application of U.S. Patent 5,802,641 by:

INVENTOR: Kip Van Steenburg  
Citizenship: US  
Post Office Address/ Residence: 38 Lakewood Drive  
Sudbury, Massachusetts 01776

Assignee: Amatech Corporation

For: LEG HOLDER SYSTEM FOR SIMULTANEOUS POSITIONING IN THE ABDUCTION AND LITHOTOMY DIMENSIONS

Enclosed are:

The Specification, including claims and abstract (24 pages);  
6 sheets of 6 formal drawing(s);  
Unexecuted Statement under 37 CFR 3.73(b);  
Unexecuted Offer to Surrender Original Patent under 37 CFR 1.178;  
Unexecuted Declaration by Inventor;  
Request for Title Report.

SEP - 7 2000

The filing fee has been calculated as shown below:

For	No. Filed		No. Extra	Small/Large Entity	Total
Basic Fee:				+\$345/690=	\$ 690.00
Total Claims:	100	- 20 =	80	x \$9/18 =	\$1,440.00
Independent Claims:	7	- 3 =	4	x \$39/78 =	\$ 312.00
Multiple Dep. Claim Presented:	0			+\$130/260	\$ 0.00
<b>TOTAL FEES:</b>					<b>\$2,442.00</b>

A check for the filing fee in the amount of \$2,442.00 is enclosed. The Commissioner is hereby authorized to charge any additional fees which may be required, or credit any overpayment to Account No. 02-1010 (7175/65430).

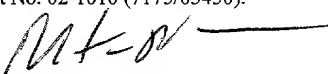
  
Mark M. Newman  
Reg. No. 31,472

Barnes & Thornburg  
Franklin Tower Bldg.  
1401 Eye Street, N.W.  
Suite 500  
Washington, D.C. 20005  
(202) 289-1313

MMN 39448

09690433 09/07/00

IN THE UNITED STATES PATENT AND TRADEMARK OFFICE

Applicant: Van Steenburg  
Serial No.: unknown Art Unit: unknown  
Filed: herewith Examiner: unknown  
For: Reissue of U.S. Patent No. 5,802,641  
Issued September 8, 1998  
on U.S. Application Serial No. 813,708  
Filed March 7, 1997

STATEMENT UNDER 37 CFR 3.73(b)

Assistant Commissioner  
for Patents  
Washington, D.C. 20231

SEP - 7 2000

Sir:

Amatech Corporation. hereby certifies that it is the assignee of the entire right, title, and interest in the patent application identified above by virtue of an Assignment from the inventor of said patent application to Amatech Corporation, which is recorded at Reel 010188, Frame 0724.

The undersigned has reviewed all of the documents in the chain of title of the patent application identified above and, to the best of the undersigned's knowledge and belief, title is in Amatech Corporation. The undersigned, whose title is supplied below, is empowered to act on behalf of Amatech Corporation.

I hereby declare that all statements made herein of my own knowledge are true and that all statements made on information and belief are believed to be true; and further, that these statements are made with the knowledge that willful false statements, and the like so made, are punishable by fine or imprisonment, or both, under Section 1001, Title 18 of the United States

004000 000000

IN THE UNITED STATES PATENT AND TRADEMARK OFFICE

Applicant: Van Steenburg

Serial No.: unknown Art Unit: unknown

Filed: herewith Examiner: unknown

For: Reissue of U.S. Patent No. 5,802,641  
Issued September 8, 1998  
on U.S. Application Serial No. 813,708  
Filed March 7, 1997

OFFER TO SURRENDER ORIGINAL PATENT UNDER 37 C.F.R. § 1.178

Assistant Commissioner  
for Patents  
Washington, D.C. 20231

SEP - 7 2000

Sir:

The undersigned, Assignee for the accompanying application for the reissue of U.S. Letters Patent No.5,802,641, for LEG HOLDER SYSTEM FOR SIMULTANEOUS POSITIONING IN THE ABDUCTION AND LITHOTOMY DIMENSIONS, issued on September 8, 1998, of which Amatech Corporation is now the sole owner by Assignment, and on whose behalf the accompanying application is made, hereby offers to surrender said Letters Patent. Filed herewith is an order for a title report as required in such cases.

\_\_\_\_\_  
Date

\_\_\_\_\_  
Name

002060-EPH0950

Code, and that such willful false statements may jeopardize the validity of the application or any patent issuing thereon.

Date: \_\_\_\_\_

Name: \_\_\_\_\_

Title: \_\_\_\_\_

Signature: \_\_\_\_\_

0000000000000000000000000000000000

Attorney Docket No. 7175/65430  
PATENT

IN THE UNITED STATES PATENT AND TRADEMARK OFFICE

SPECIFICATION

**INVENTION:** LEG HOLDER SYSTEM FOR SIMULTANEOUS POSITIONING IN  
THE ABDUCTION AND LITHOTOMY DIMENSIONS

**INVENTOR:** Kip Van Steenburg  
**Citizenship:** US  
**Post Office Address/** 38 Lakewood Drive  
**Residence:** Sudbury, Massachusetts 01776

**ATTORNEYS:** BARNES & THORNBURG  
1313 Merchants Bank Building  
11 S. Meridian Street  
Indianapolis, Indiana 46204  
(317) 236-1313

# LEG HOLDER SYSTEM FOR SIMULTANEOUS POSITIONING IN THE ABDUCTION AND LITHOTOMY DIMENSIONS

## FIELD OF INVENTION

This invention relates to an improved leg holder system and more particularly to such a system in which adjustment in both the lithotomy and abduction dimensions can be made simultaneously with a single action.

## BACKGROUND OF INVENTION

In recent years many newer surgical procedures have required interoperative positioning of patients legs. Until recently such positioning typically required adjusting the leg holder's mounting clamp located on the surgical table siderail, beneath the sterile drape. This raised concerns about possible violation of the sterile field and it limited the performance of such adjustments to non-sterile personnel. Recent attempts to solve this problem yielded leg holders that could be raised and lowered through the drapes, however, they have several limitations. First, when adjusted upwardly they lock by means of a ratchet mechanism; this mechanism does not prevent further unintended upward movement of the legs that could result from tilting the patient in the extreme head down direction "Trendelenburg" or from surgical staff leaning against the leg holder. Secondly, abduction is predetermined and cannot be adjusted without accessing the mounting clamp.

## SUMMARY OF INVENTION

It is therefore an object of this invention to provide an improved leg holder system.

It is a further object of this invention to provide such a system with which both the lithotomy and abductions for a leg holder can be adjusted with a single action with one hand.

It is a further object of this invention to provide such a system which permits adjustment without violating the sterile field.

It is a further object of this invention to provide such a system which prevents further inadvertent upward movement even when the patient is tilted in the extreme head down or Trendelenburg direction.

It is a further object of this invention to provide such a system which when locked prevents movement in all directions.

It is a further object of this invention to provide such a system which permits a full abduction adjustment range throughout the full lithotomy range.

It is a further object of this invention to provide such a system which the clamps are normally locked and must be activated for release.

It is a further object of this invention to provide such a system which release of the actuation of the clamps causes them to default to the locked condition.

It is a further object of this invention to provide such a system in which the clamps are remotely operable.

It is a further object of this invention to provide such a system in which the clamping operation is accomplished through the same instrumentality as the re-positioning of the leg holders.

It is a further object of this invention to provide such a system in which the leg holders are counterbalanced for reducing the load encountered by the user with a patient in place.

It is a further object of this invention to provide such a system in which the operation of the clamping means can be accomplished with the same action as the repositioning of the leg holders or can be decoupled for independent operation.

This invention results from the realization that a truly simple, fail-safe leg holder system which enables simultaneous positioning in the abduction and lithotomy dimensions with a single action outside the sterile field can be effected using an actuator that is normally biased to clamp both the leg cradle support device and a mounting device which have a mutually transverse axes and under control of a remote operator simultaneously releases the clamping force in both devices to enable movement of the support device about both axes for repositioning in both the abduction and lithotomy dimensions.

This invention features a leg holder system for simultaneous positioning in the abduction and lithotomy dimensions. There is a support device for supporting a leg cradle and a clamping device for mounting the proximate end of the support device to a mounting device having a first axis and selectively clamping and releasing motion of the support device about the first axis and about a second axis transverse to the first axis. An actuator device actuates the clamp to selectively clamp and release simultaneously the support device and the mounting device. An operator device remote from the clamping device and actuator device operates the actuator device to enable the support device to move simultaneously about both the first and second axes in the abduction and lithotomy dimensions.

In a preferred embodiment the clamping device may include a pair of pressure blocks a first recess for receiving the mounting device and a second recess for receiving a support device. The clamping device may include a device for biasing the blocks to normally produce friction between the recesses and their respective mounting and support devices to clamp them in position. The actuator device may include an actuator rod extending with a support device. The support device may include a bore and the actuator rod may be disposed in the bore. The actuator device may include a camming device fixed to the actuator rod and a follower device disposed in the clamping device and responsive to the camming device for opposing the biasing device to simultaneously decrease the friction force on the support device and on the mounting device to release the clamping device in both axes. The operator device may include a handle for both operating the actuator device to remotely release and secure the clamping device to the support device and the mounting device and to position the support device in the abduction and lithotomy dimensions. The support device may include a resilient device for counterbalancing the weight of the leg holder. The axis of the handle may be coincident with the axis with the actuator rod for independent actuation of the clamping device and motion of the support device in the lithotomy and abduction dimensions. The handle may include a rotatable sleeve. The support device may include a leg cradle bracket for mounting a leg cradle spaced from the axis of the support means. The actuator device may include a limiter device for arresting movement of the camming device before its highest position to enable the biasing device to back-drive the camming device when the operator device is released and automatically reestablish the clamping function between the recesses and the support and mounting devices.

#### DISCLOSURE OF PREFERRED EMBODIMENT

Other objects, features and advantages will occur to those skilled in the art from the following description of a preferred embodiment and the accompanying drawings, in which:



FIG. 1 is a detailed sectional view of a leg holder system with portions broken away and foreshortened of a leg holder system according to this invention;

FIG. 2 is a view similar to FIG. 1, with the support device rotated 90°;

FIG. 3 is an exploded view of the leg holder system shown in FIGS. 1 and 2;

FIG. 4 is a pair of leg holder systems according to this invention as shown in FIGS. 1, 2 and 3 installed on an x-ray table with leg cradles and leg cradle clamps installed and employing gas cylinder lift assistance devices;

FIG. 5 is a view similar to FIG. 4 with the leg cradles repositioned with greater abduction and lesser lithotomy; and

FIG. 6 is a view similar to FIG. 4 with the leg cradles repositioned with greater lithotomy and lesser abduction.

There is shown in FIG. 1, leg holder system 10 according to this invention which enables simultaneous positioning in the abduction and lithotomy dimensions. Leg holder system 10 includes support device 12 for supporting a leg cradle not shown in FIG. 1, but seen in FIGS. 4, 5, and 6. System 10 also includes a clamping device 14, actuator device 16, and an operator device, handle 18. Support device 12 includes a hollow tube 20 which has its proximal end 22 located in clamping device 14 and its distal end 24 at handle 18. Limiter device 26 shown more completely in FIG. 3, is mounted at the distal end 24 of hollow tube 20. Clamping device 14 includes a clamp housing 30 having a recess 32 which receives and clamps a mounting device such as pivot post 34 extending from an x-ray table. Clamp housing 30 is rotatable about axis 36 of pivot post 34 which allows motion in the abduction dimension indicated by arrow 35.

Clamp housing 30 also includes a bore 38 which receives pressure blocks 40 and 42. Pressure block 40 has a bore 44 through it which receives the body 46 of pressure block 42. The enlarged tapered head 48 of pressure block 40 fits in the enlarged tapered bore 50 of clamp housing 30. Enlarged tapered head 52 of pressure block 42 fits in an enlarged tapered bore 54 of clamp housing 30. The distal end 56 of pressure block 42 includes threads 58 which mate with threads 60 on locking nut 62. The enlarged head 64 of locking nut 62 engages one of two oppositely facing Belleville washers 66 and 68 located in recess 69. Thus, when locking nut 62 is tightened down on pressure block 42 it compresses the Belleville washers 66 and 68. This causes the tapered portions 48 and 52 of pressure blocks 40 and 42 the force of the Belleville washers to be drawn tightly inwardly against the tapered surfaces 50 and 54 of clamp housing 30. This wedging effect insures a good tight clamping force which brings clamp housing together by narrowing gap 70 and thereby tightening recess 32 about pivot post 34 and simultaneously wedging pressure blocks 42 and 40 tightly in the tapered recesses 50 and 54, respectively, so that they are held against rotation in the lithotomy dimension about their central axis 72 as shown by arrow 74.

Thus, in the normal condition locking nut 62 is tightened down sufficiently to compress Belleville washers 66 and 68 so that a clamping force is applied to prevent rotation 74 about axis 72 in the lithotomy dimension and prevent rotation 35 about axis 36 in the abduction dimension. Release of both of these clamping forces in both dimensions is accomplished simultaneously by rotating handle 18 about axis 80 as indicated by arrow 82. This rotation causes actuator rod 84 to rotate along with actuator member 86 which is fixed by pin 88 to rotate with rod 84. Pressure block 42 includes a bore 75 which is larger than but coaxially

aligned with a similar bore 76 in pressure block 40. The proximal end 22 of tube 20 of support device 12 passes through bores 75 and 76 and is fixed or force fitted to bore 76 so that when handle 18 and tube 20 of support device 12 are rotated up out of the paper as indicated by arrow 77 the entire pressure block assembly including pressure blocks 40 and 42 is rotated with tube 20.

Actuator member 16 includes two bearing portions 90 and 92 which receive needle bearings 94 and 96 that enable rod 84 to rotate smoothly within tube 20. Bearing 96 is supported in journal 98 fitted in the end of tube 20. Between bearing portions 90 and 92 is eccentric portion 100 which also supports a needle bearing 102. Riding on needle bearing 102 is follower 104 which extends through bore 106 in the proximal end 22 of tubing 20. The end 108 of follower 104 is cylindrically shaped to engage the cylindrical shape of needle bearing 102. The other end 110 is concave or cup shaped to engage the spherical tip 112 of set screw 114 which is threadably engaged in bore 116 of pressure block 42. Thus, when handle 82 is rotated about axis 80 it rotates the eccentric portion 100 to bear on follower 104 which in turn exerts an outward force on set screw 116. As a result there is a force directed along axis 72 which opposes the bias of Belleville washers 66 and 68 thereby releases the force of pressure blocks 40 and 42 on tapered portions 50 and 54 of clamp housing 30. This allows clamp housing 30 to spread somewhat thereby increasing the length of gap 70 so that recess 32 relaxes its grip on pivot post 34 and permits rotation as indicated by arrow 35 in the abduction direction and simultaneously permits pressure blocks 40 and 42 to rotate in the tapered recesses 50 and 54 so that actuator rod 84 and tube 20 of support device 12 can be rotated in a direction out of or into the paper as indicated by arrow 77.

Thus with one action, the rotation of handle 18 about axis 80, the clamp releases its grip to allow rotation about both axis 36 and axis 72 to provide simultaneous repositioning in the abduction and lithotomy dimensions. When the handle is released the force of Belleville washers 66 and 68 back-rotate the eccentric, snapping the handle to the normal position and allowing the Belleville washer to reinstate the clamping force on both axes. Covers 120 and 122 may be installed to cover the heads of pressure blocks 40 and 42, respectively.

The rotation of support device 12 in the direction of arrow 77, FIG. 1, is shown in FIG. 2, where upon the rotation of handle 18 about axis 80 and the application of eccentric 100 to counteract the clamping force of Belleville washers 66 and 68, the entire support device 12 including tube 20 and the actuator rod 84 have been rotated from the plane of the paper in FIG. 1, to the upright position where tube 20 and actuator rod 84 are perpendicular to the plane of the paper in FIG. 2.

The rotational symmetry as well as rotational action may be better understood with reference to the exploded three dimensional view in FIG. 3. Also shown in FIG. 3 is collar 130 which is held to the end of tube 20 by means of set screw 132 and the limiter collar 26a on the other end of tube 20 which is held there by means of set screws 140 and 142. A circumferential slot 144 which extends less than all the way around the circumference of limiter collar 26a receives limiter pin 146 fixed to rotate with actuator rod 84. A pair of bushings 148 and 150 are mounted on either end of limiter pin 146 after it is mounted in hole 152 of actuator rod 84 to provide for a smoother rotation within slot 144. It is limiter pin 146 in conjunction with the limited extent of slot 144 that arrests the rotation of actuator rod 84 before it reaches top dead center on the cam so that upon release by the human

operator of handle 18 the handle and actuator rod 84 snap back to the position where they do not oppose the force of Belleville washer 66 and 68 and so the Belleville washers reinstate the fail-safe clamping force on both axes. Handle 18 is rotatably mounted on pin 160 which is mounted for rotation about axis 85 on pin 162. Pin 62 includes a groove 164 that allows it and handle 160 to rotate about axis 85 but which engages with spring loaded balls 166 and 168 that prevent the handle 160 and pin 162 from being withdrawn from the hollow end 170 of actuator rod 84.

Although thus far the system can be shown as actuated by mechanical device namely, the action of eccentric 100. This is not a necessary limitation of the invention, for example, any device may be substituted for eccentric 100 which will exert the opposing force on follower 104 or a similar device to release the action of Belleville washers 66 and 68 on the pressure blocks and clamp pressure blocks 40 and 42 and clamp housing 30. For example, a hydraulic piston could be installed in place of eccentric 100 driven through hydraulic lines by a foot pedal, for example, which would be remote from the device and external to the sterile drapes. Similarly an electrical device having a movable armature could be used in the same fashion or even a piezo electric crystal or similar device when only small mechanical movements are required.

Typically, in use, two such systems 10a and 10b are used in conjunction with an x-ray table 180, FIG. 4. X-ray table 180 includes two rails 182 and 184 on which slide blocks 186 can be slid into and out of the plane of the paper and tightened at a desired location by handles 190 and 192. Pivot posts 34a and 34b extend upward from clamps 186 and 188 into recesses 32a and 32b, not shown, of clamp housings 30a and 30b. Mounted on each support device 20a and 20b are leg cradles (leg holders) 200 and 202 pivotally mounted on axes 204 and 206 which are spaced from the axes 80a and 80b of tubes 20a and 20b by support shafts 208 and 210 which are supported in clamps 212 and 214 that are clamped into position on tubes 20a and 20b by handles 216 and 218. The lifting of the weight of this system including cradles 200 and 202 and the legs of the patient may be assisted by means of springs or gas cylinders or other devices as symbolically indicated by gas cylinders 220 and 222 mounted to support tubes 20a and 20b by clamps 224 and 226 and mounted to pivot posts 34a and 34b by clamps 228 and 230.

In FIG. 4, cradles 200 and 202 are in a midrange position with respect to the lithotomy and abduction dimensions. By simply gripping handles 18a and 18b and rotating them in the direction of arrows 230 and 232 the eccentric members are engaged opposing the Belleville washer force and freeing up and releasing the clamping action on both axes 32a and 32b and axes 72a and 72b. Now by simply moving the handles downwardly as indicated by arrows 240 and 242 the cradles 200 and 202, FIG. 5, can be moved to a lower position in the lithotomy dimension and may be spread farther apart in the abduction dimension as shown in FIG. 5, or alternatively the same motion of handles 18a and 18b in FIG. 4, which releases the clamp in both dimensions. After the operation of both of them which releases them in both dimensions the handles 18a and 18b can be moved upwardly to increase the position in the lithotomy dimension and reduce somewhat the position in the abduction dimension as shown in FIG. 6. In each case upon the accidental or

intentional release of the handles 18a and 18b the limiter device allows the Belleville washers to snap the handles and the actuator rods and the eccentric out of position so that the Belleville washers, once more in a fail-safe mode, apply the clamping force in both dimensions.

Although specific features of this invention are shown in some drawings and not others, this is for convenience only as each feature may be combined with any or all of the other features in accordance with the invention.

Other embodiments will occur to those skilled in the art and are within the following claims:

What is claimed is:

1. A leg holder system for simultaneous positioning in an abduction dimension and a lithotomy dimension comprising:

a support device, having a longitudinal axis, for supporting a leg cradle;

a clamping device for mounting a proximate end of said support device to a mounting device having a first axis transverse to said longitudinal axis and selectively simultaneously clamping and releasing motion of said support device about said first axis and about a second axis transverse to both said first axis and said longitudinal axis, said support device fixed in said clamping device from rotation about said longitudinal axis;

an actuator device for actuating said clamping device to simultaneously selectively clamp and release said support device and said mounting device; and

an operator device remote from said clamping device and said actuator device for operating said actuator device to enable said support device to move jointly about both said first and said second axes in the abduction and lithotomy dimensions.

2. The leg holder system of claim 1 in which said clamping device includes a pair of pressure blocks, a first recess for receiving said mounting device and a second recess for receiving said support device.

3. The leg holder system of claim 2 in which said clamping device includes a biasing device for biasing said blocks to normally produce friction between said recesses and their respective mounting and support devices to clamp them in position.

4. The leg holder system of claim 1 in which said actuator device includes an actuator rod extending with said support device.

5. The leg holder system of claim 4 in which said support device includes a bore and said actuator rod is disposed in said bore.

6. The leg holder system of claim 4 in which said actuator device includes a camming device fixed to said actuator rod and a follower device disposed in said clamping device and responsive to said camming device for opposing said biasing device to simultaneously decrease the friction force on said support device and on said mounting device to release the clamping device in both axes.

7. The leg holder system of claim 1 in which said operator device includes a handle for both operating said actuator device to remotely release and secure said clamping device to said support device and said mounting device and to position said support device in the abduction and lithotomy dimensions.

8. The leg holder system of claim 1 in which said support device includes a resilient device for counterbalancing the weight borne by said support device.

002060 E409560

9. The leg holder system of claim 6 in which said operator device includes a handle for both operating said actuator device to remotely release and secure said clamping device to said support device and said mounting device and to position said support device in the abduction and lithotomy dimensions.

10. The leg holder system of claim 9 in which the axis of said handle is coincident with the axis of said actuator rod for independent actuation of said clamp device and motion of said support device in the lithotomy dimension.

11. The leg holder system of claim 7 in which said handle includes a rotatable sleeve.

12. The leg holder system of claim 1 in which said support device includes a cradle bracket for mounting a leg cradle spaced from said longitudinal axis of said support means.

13. The leg holder system of claim 6 in which said actuator device includes a limiter device for arresting movement of said camming device before its highest position to enable said biasing device to back-drive said camming device when said operator device is released and automatically re-establish the clamping friction between said recesses and said support and mounting devices.

002080-8403360

14. A leg positioning apparatus comprising a support device,

a leg cradle coupled to the support device and movable about a first plurality of axes relative to the support device,

a clamping device coupling the support device to a mounting device, the clamping device being configured to clamp the motion of the support device relative to the mounting device and to release the support device for rotative movement relative to the mounting device about a second plurality of axes, the leg cradle being movable about the first plurality of axes when the support device is clamped against movement about the second plurality of axes,

an actuator device configured to move the clamping device to selectively clamp and release the support device relative to the mounting device, and

an operator device remote from the clamping device and remote from the actuator device, the operator device being operatively coupled to the actuator device, the operator device being configured to operate the actuator device.

15. The leg positioning apparatus of claim 14, wherein the second plurality of pivot axes includes a first axis about which the support device rotates in an abduction dimension and a second axis about which the support device rotates in a lithotomy dimension.

16. The leg positioning apparatus of claim 14, wherein the support device comprises an elongated member having a proximal end coupled to the clamping device and a distal end spaced apart from the clamping device.

17. The leg positioning apparatus of claim 16, wherein the operator device is positioned to lie adjacent the distal end of the elongated member.

18. The leg positioning apparatus of claim 17, wherein the distal end of the elongated member is positioned to lie between the operator device and the clamping device.

19. The leg positioning apparatus of claim 16, wherein the elongated member includes a tube having an elongated channel therethrough, an element coupling the operator device to the clamping device, and the element being positioned to lie in the channel.

20. The leg positioning apparatus of claim 19, wherein the element is a rod that rotates in the channel to operate the actuator device.

21. The leg positioning apparatus of claim 14, wherein the clamping device includes a housing formed to include a tapered bore and a pressure block configured to wedge against the tapered bore to clamp the clamping device against rotation about the second plurality of axes.

22. The leg positioning apparatus of claim 21, wherein the housing includes a recess configured to receive the mounting device and the pressure block being biased to tighten the recess of the housing against the mounting device.

23. The leg positioning apparatus of claim 22, wherein the clamping device includes at least one Belleville washer to bias the pressure block to wedge against the tapered bore.

24. A leg positioning apparatus comprising  
a mounting device,  
an elongated member,  
a leg holder adapted to engage and support at least a portion of a leg of a patient,  
a coupler configured to couple the leg holder to the elongated member, the coupler being configured to permit adjustment of a position of the leg holder relative to the elongated member about a first plurality of axes,

a locking device coupled to the mounting device and coupled to the elongated member, the locking device being movable between a locking position in which the elongated member is fixed relative to the mounting device and a releasing position in which the elongated member is rotatable about a second plurality of axes relative to the mounting device, and



an operator device coupled to the elongated member and operatively coupled to the locking device, the coupler being positioned to lie between the operator device and the locking device, the operator device being movable to move the locking device between the locking position and the releasing position.

25. The leg positioning apparatus of claim 24, wherein the mounting device includes a post that defines one axis of the second plurality of axes and the elongated element is movable about the post when the locking device is in the releasing position.

26. The leg positioning apparatus of claim 25, wherein the locking device includes a member that clamps against the post when the locking device is in the locking position.

27. The leg positioning apparatus of claim 25, wherein the mounting device includes a block adapted to be coupled to an accessory rail of a patient-support table and the post is coupled to the block.

28. The leg positioning apparatus of claim 25, further comprising a resilient device configured to counterbalance weight supported by the leg holder, the resilient device being coupled to the post, and the resilient device being coupled to the elongated member.

29. The leg positioning apparatus of claim 24, wherein the elongated member includes a proximal end coupled to the locking device and a distal end spaced apart from the proximal end, and the operator device is adjacent the distal end of the elongated member.

30. The leg positioning apparatus of claim 29, wherein the distal end of the elongated member is between the operator device and the locking device.

31. The leg positioning apparatus of claim 24, wherein the elongated member defines a longitudinal axis and the operator device rotates about the longitudinal axis to move the locking device between the locking position and the releasing position.

002000 E409560

32. The leg positioning apparatus of claim 24, further comprising a rod coupled to the operator device and extending therefrom toward the locking device.

33. The leg positioning apparatus of claim 32, wherein the elongated member includes a tube having a passage therethrough and the rod is positioned to lie in the passage.

34. The leg positioning apparatus of claim 32, wherein a portion of the tube and a portion of the rod extend through the coupler.

35. The leg positioning apparatus of claim 24, wherein the locking device includes a member that is yieldably biased against the mounting device when the locking device is in the locking position.

36. The leg positioning apparatus of claim 24, wherein the mounting device includes a post and the locking device includes a housing formed to include a recess receiving the post and a gap extending radially therefrom and having a transverse length so that increasing the length of the gap permits rotation of the housing relative to the post.

37. The leg positioning apparatus of claim 36, wherein the recess defines a first axis of the second plurality of axes and the housing is formed to include a bore defining a second axis of the second plurality of axes.

38. The leg positioning apparatus of claim 37, wherein the second axis is generally orthogonal to the first axis.

39. The leg positioning apparatus of claim 37, wherein the locking device further comprises first and second pressure blocks received by the bore, the first pressure block being movable relative to the second pressure block within the bore, the first and second pressure blocks engaging the housing and being configured so that the movement of the first pressure block toward

the second pressure block decreases the length of the gap of the housing and the housing grips the post, thereby blocking rotation of the housing relative to the post.

40. The leg positioning apparatus of claim 24, wherein the locking device includes a housing, a first pressure block received by the housing, a second pressure block received by the housing, and a spring received by the housing and acting to yieldably bias the first pressure block toward the second pressure block.

41. The leg positioning apparatus of claim 40, wherein the first pressure block comprises a proximal end, a distal end, and a head formed on the distal end and the second pressure block comprises a proximal end, a distal end, and a head formed on the distal end, and wherein the first and second pressure blocks are movable between an inward position at which the head of the first pressure block and the head of the second pressure block frictionally engage the housing to block rotation of the first and second pressure blocks relative to the housing and an outward position permitting rotation of the first and second pressure blocks relative to the housing.

42. The leg positioning apparatus of claim 41, wherein at least one of the first and second pressure blocks is formed to include a bore receiving the elongated member so that the elongated member rotates relative to the housing when the first and second pressure blocks rotate relative to the housing and so that movement of the elongated member relative to the housing is blocked when the first and second pressure blocks are at the inward position.

43. The leg positioning apparatus of claim 41, wherein the mounting device includes a post, the housing is formed to include a recess receiving the post and a gap extending radially therefrom, the gap having a transverse length so that increasing the length of the gap permits rotation of the housing relative to the post and so that movement of the first and second pressure blocks to the inward position decreases the length of the gap thereby blocking rotation of the housing relative to the post.





56. The leg positioning apparatus of claim 48, further comprising a rod coupled to the operator device and extending therefrom toward the clamping device.

57. The leg positioning apparatus of claim 56, wherein the tube includes a passage therethrough and the rod is positioned to lie in the passage.

58. The leg positioning apparatus of claim 56, wherein a portion of the tube and a portion of the rod extend through the coupler.

59. The leg positioning apparatus of claim 48, wherein the clamping device includes a member that is yieldably biased against the mounting device when the clamping device is in the normal condition.

60. The leg positioning apparatus of claim 48, wherein the mounting device includes a post and the clamping device includes a housing formed to include a recess receiving the post and a gap extending radially therefrom and having a transverse length so that increasing the length of the gap permits rotation of the housing relative to the post.

61. The leg positioning apparatus of claim 60, wherein the recess defines a first axis of the plurality of axes and the housing is formed to include a bore defining a second axis of the plurality of axes.

62. The leg positioning apparatus of claim 61, wherein the second axis is generally orthogonal to the first axis.

63. The leg positioning apparatus of claim 61, wherein the clamping device further comprises first and second pressure blocks received by the bore, the first pressure block being movable relative to the second pressure block within the bore, the first and second pressure blocks engaging the housing and being configured so that the movement of the first pressure block toward

002050 E4099500

the second pressure block decreases the length of the gap of the housing and the housing grips the post, thereby blocking rotation of the housing relative to the post.

64. The leg positioning apparatus of claim 48, wherein the clamping device includes a housing, a first pressure block received by the housing, a second pressure block received by the housing, and a spring received by the housing and acting to yieldably bias the first pressure block toward the second pressure block.

65. The leg positioning apparatus of claim 64, wherein the first pressure block comprises a proximal end, a distal end, and a head formed on the distal end and the second pressure block comprises a proximal end, a distal end, and a head formed on the distal end, and the first and second pressure blocks are movable between an inward position at which the head of the first pressure block and the head of the second pressure block frictionally engage the housing to block rotation of the first and second pressure blocks relative to the housing and an outward position permitting rotation of the first and second pressure blocks relative to the housing.

66. The leg positioning apparatus of claim 65, wherein at least one of the first and second pressure blocks is formed to include a bore receiving the tube so that the tube rotates relative to the housing when the first and second pressure blocks rotate relative to the housing and so that movement of the tube relative to the housing is blocked when the first and second pressure blocks are at the inward position.

67. The leg positioning apparatus of claim 65, wherein the mounting device includes a post, the housing is formed to include a recess receiving the post and a gap extending radially therefrom, the gap having a transverse length so that increasing the length of the gap permits rotation of the housing relative to the post and so that movement of the first and second pressure blocks to the inward position decreases the length of the gap thereby blocking rotation of the housing relative to the post.

68. The leg positioning apparatus of claim 48, wherein the clamping device includes a housing and first and second pressure blocks received by the housing and movable relative to one another between an inward position at which the clamping device is in the normal condition and an outward position at which the clamping device is in the release condition.

69. The leg positioning apparatus of claim 68, further comprising an actuator device operatively coupling the operator device to at least one of the first and second pressure blocks, the actuator device being movable between a first position at which the first and second pressure blocks are at the outward position and a second position at which the first and second pressure blocks are at the inward position.

70. The leg positioning apparatus of claim 69, wherein the operator device includes a handle and further comprising a rod coupled to the handle, the rod being coupled to the actuator device so that movement of the handle moves the actuator device.

71. The leg holder system of claim 68, wherein the actuator device includes an eccentric portion, one of the first and second pressure blocks comprises a follower portion, the eccentric portion engaging the follower portion to move the first and second pressure blocks to the outward position when the actuator device is rotated in a first direction.

72. A leg positioning apparatus comprising  
a mounting device,  
a hollow tube having a bore, the tube being lockable relative to the mounting device and releasable to rotate relative to the mounting device about a plurality of axes,  
a clamp spaced apart from the mounting device and coupled to the tube such that the tube passes through the clamp,  
a leg holder coupled to the clamp,  
a handle movable relative to the tube, and  
an actuator coupled to the handle, at least a portion of the actuator extending through the bore of the tube, the portion of the actuator extending through the bore also passing through the





80. The leg positioning apparatus of claim 72, further comprising a resilient device configured to counterbalance the weight supported by the leg holder, the resilient device being coupled to the mounting device, and the resilient device being coupled to the tube.

81. A leg positioning apparatus comprising a mounting device,

an elongated element lockable relative to the mounting device and releasable to rotate relative to the mounting device about a plurality of axes,

a handle coupled to the elongated element and movable relative to the elongated element to release the elongated element to allow for rotative repositioning of the elongated element about the plurality of axes relative to the mounting device, and

a leg holder coupled to the elongated member between the handle and the mounting device, the leg holder being movable relative to the elongated element when the elongated element is locked relative to the mounting device.

82. The leg positioning apparatus of claim 81, wherein the elongated element includes a proximal end adjacent the mounting device, the elongated element includes a distal end spaced apart from the proximal end, and the handle is adjacent the distal end.

83. The leg positioning apparatus of claim 82, wherein the distal end of the tube is positioned to lie between the handle and the proximal end.

84. The leg positioning apparatus of claim 81, wherein the elongated element defines a longitudinal axis and the handle rotates about the longitudinal axis to release the elongated element for rotation about the plurality of axes relative to the mounting device.

85. The leg positioning apparatus of claim 81, further comprising a locking device coupling the elongated element to the mounting device, the locking device being movable between a locked condition having the elongated element fixed relative to the mounting device and a release

002050-EEH09950

condition in which the elongated element is rotatable relative to the mounting device about the plurality of axes.

86. The leg positioning apparatus of claim 85, wherein the locking device comprises a clamping device.

87. The leg positioning apparatus of claim 85, wherein movement of the handle moves the locking device between the lock condition to the release condition.

88. The leg positioning apparatus of claim 81, further comprising a resilient device configured to counterbalance the weight supported by the leg holder, the resilient device being coupled to the mounting device, and the resilient device being coupled to the elongated element.

89. The leg positioning apparatus of claim 81, wherein the plurality of axes includes a first axis about which the elongated element rotates in an abduction dimension and a second axis about which the elongated element rotates in a lithotomy dimension.

90. The leg positioning apparatus of claim 81, wherein the mounting device includes a block adapted to be coupled to an accessory rail of a patient-support table.

91. A leg positioning apparatus comprising  
a mounting device,  
a support device lockable relative to the mounting device and releasable to rotate relative to the mounting device about a first plurality of axes,  
a leg holder lockable relative to the support device and releasable to move relative to the support device about a second plurality of axes,  
a first handle movable to lock the support device from rotation about the first plurality of axes relative to the mounting device and movable to unlock the support device for rotation about the first plurality of axes relative to the mounting device, and

a second handle movable to lock the leg holder from moving about the second plurality of axes relative to the support device and movable to unlock the leg holder for movement about the second plurality of axes relative to the support device.

92. The leg positioning apparatus of claim 91, wherein the support device includes a proximal end adjacent the mounting device, the support device includes a distal end spaced apart from the proximal end, and the first handle is adjacent the distal end.

93. The leg positioning apparatus of claim 92, wherein the second handle is positioned to lie between the first handle and the proximal end.

94. The leg positioning apparatus of claim 91, wherein the support device defines a longitudinal axis and the first handle rotates about the longitudinal axis to release the support device for rotation about the first plurality of axes relative to the mounting device.

95. The leg positioning apparatus of claim 91, further comprising a locking device coupling the support device to the mounting device, the locking device being movable between a lock condition having the support device fixed relative to the mounting device and a release condition in which the supported device is rotatable relative to the mounting device about the first plurality of axes.

96. The leg positioning apparatus of claim 95, wherein the locking device comprises a clamping device.

97. The leg positioning apparatus of claim 95, wherein movement of the first handle moves the locking device between the lock condition to the release condition.

98. The leg positioning apparatus of claim 91, further comprising a resilient device configured to counterbalance weight supported by the leg holder, the resilient device being coupled to the mounting device, and the resilient device being coupled to the support device.







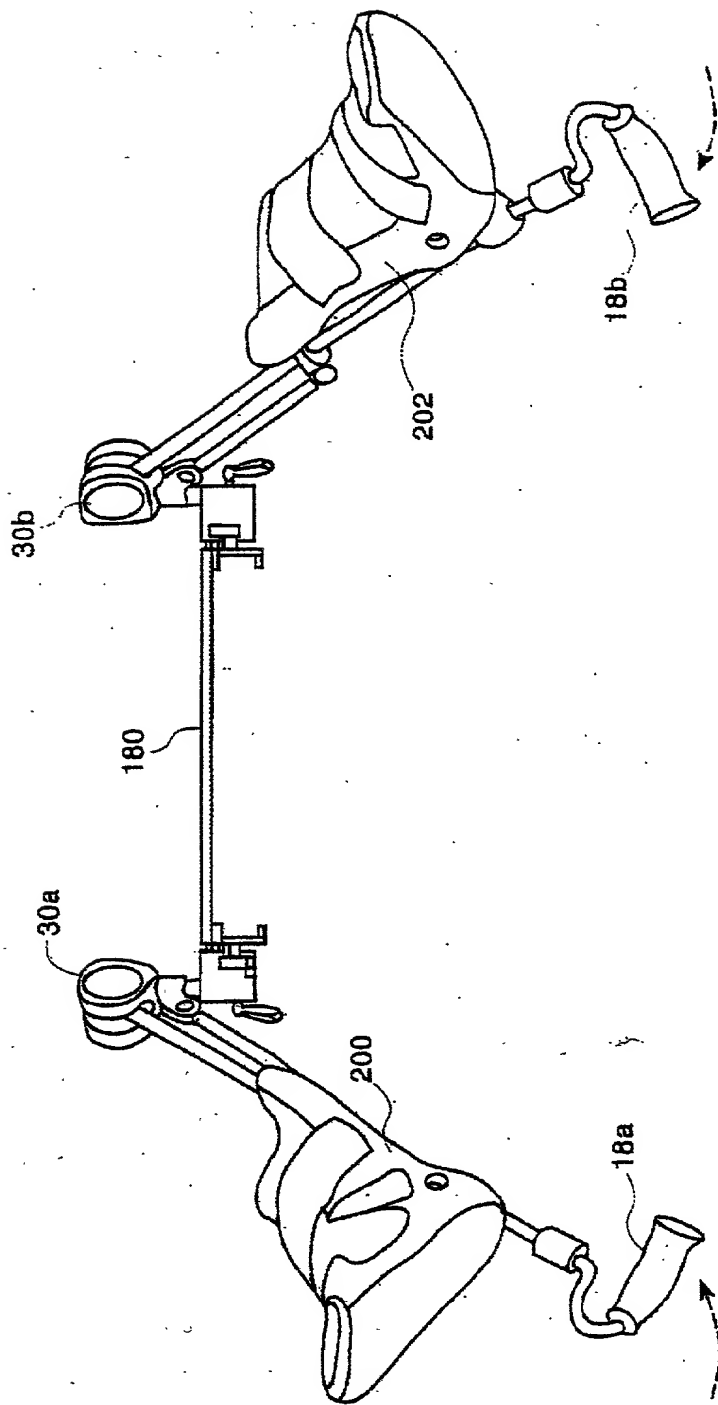







FIG. 5





IN THE UNITED STATES PATENT AND TRADEMARK OFFICE

Applicant: Van Steenburg  
Serial No.: unknown Art Unit: unknown  
Filed: herewith Examiner: unknown  
For: Reissue of U.S. Patent No. 5,802,641  
Issued September 8, 1998  
on U.S. Application Serial No. 813,708  
Filed March 7, 1997

DECLARATION BY INVENTOR

Assistant Commissioner  
for Patents  
Washington, D.C. 20231

SEP - 7 2000

Sir:

I, Kip Van Steeburg declare that I am a citizen of the United States of America; that I verily believe myself to be the original and first inventors of the invention described and claimed in U.S. Letters Patent No. 5,802,641 (hereinafter '641 PATENT) and in the foregoing specification and for which invention I solicit a reissue patent; that I do not know and do not believe that said invention was ever known or used in the United States of America before my invention thereof; and that I verily believe the '641 PATENT to be wholly or partly inoperative or invalid by reason of our claiming less than I had a right to claim in the '641 PATENT.

I request that I be permitted to amend the '641 PATENT and be granted a reissue patent; that errors rendering the '641 PATENT wholly or partly inoperative or invalid caused the claims of such patent to be of more narrow scope than necessary to distinguish over the prior art; and that such errors arose without any deceptive intent.

Specifically, I at least claimed less than I had a right to claim in the '641 PATENT by limiting patent claim 1 to the supporting device to one with a longitudinal axis and the clamping device having an axis transverse to the longitudinal axis.

I have reviewed and understand the contents of the specification and claims as amended herein.

I acknowledge my duty to disclose information of which I am aware which is material to patentability as defined in Title 37, Code of Federal Regulations §1.56; and I further declare

002050 2409960

that all statements made herein of my own knowledge are true and that all statements made on information and belief are believed to be true; and further that these statements were made with knowledge that willful false statements and the like so made are punishable by fine or imprisonment or both under 18 U.S.C. § 1001, and that such willful false statements may jeopardize the validity of the application for reissue or any patent issuing thereon.

I hereby appoint William R. Coffey, Reg. No. 24023; Jerry E. Hyland, Reg. No. 20904; Richard D. Conard, Reg. No. 27321; Steven R. Lammert, Reg. No. 27653; Richard A. Rezek, Reg. No. 30796; Timothy E. Niednagel, Reg. No. 33266; John P. Breen, Reg. No. 38833; Jill L. Woodburn, Reg. No. 39874; Nancy J. Harrison, Reg. No. 27083; R. Trevor Carter, Reg. No. 40549; Dilip A. Kulkarni, Reg. No. 27510; Perry Palan, Reg. No. 26213; Mark M. Newman, Reg. No. 31472; Bobby B. Gillenwater, Reg. No. 31105; Paul B. Hunt, Reg. No. 37154; Michael S. Gzybowski, Reg. No. 32816; and Robert D. Null, Reg. No. 40746, my attorneys, with full power of substitution and revocation, to prosecute this application, and to transact all business in the Patent and Trademark Office connected therewith; and I specify that communications regarding this application to reissue be directed to:

Richard D. Conard  
BARNES & THORNBURG  
1313 Merchants Bank Building  
11 S. Meridian Street  
Indianapolis, Indiana 46204

\_\_\_\_\_  
Date

\_\_\_\_\_  
Kip Van Steenburg  
38 Lakewood Drive  
Sudbury, Massachusetts 01776

002050-ETH0360

ASSENT BY ASSIGNEE

The undersigned assignee of the entire interest in the above-mentioned Letters Patent hereby assents to the accompanying DECLARATION BY INVENTOR.

AMATECH CORPORATION

By: \_\_\_\_\_

Printed Name: \_\_\_\_\_

Title: \_\_\_\_\_

002050\*E405560